

Use and Maintenance Manual

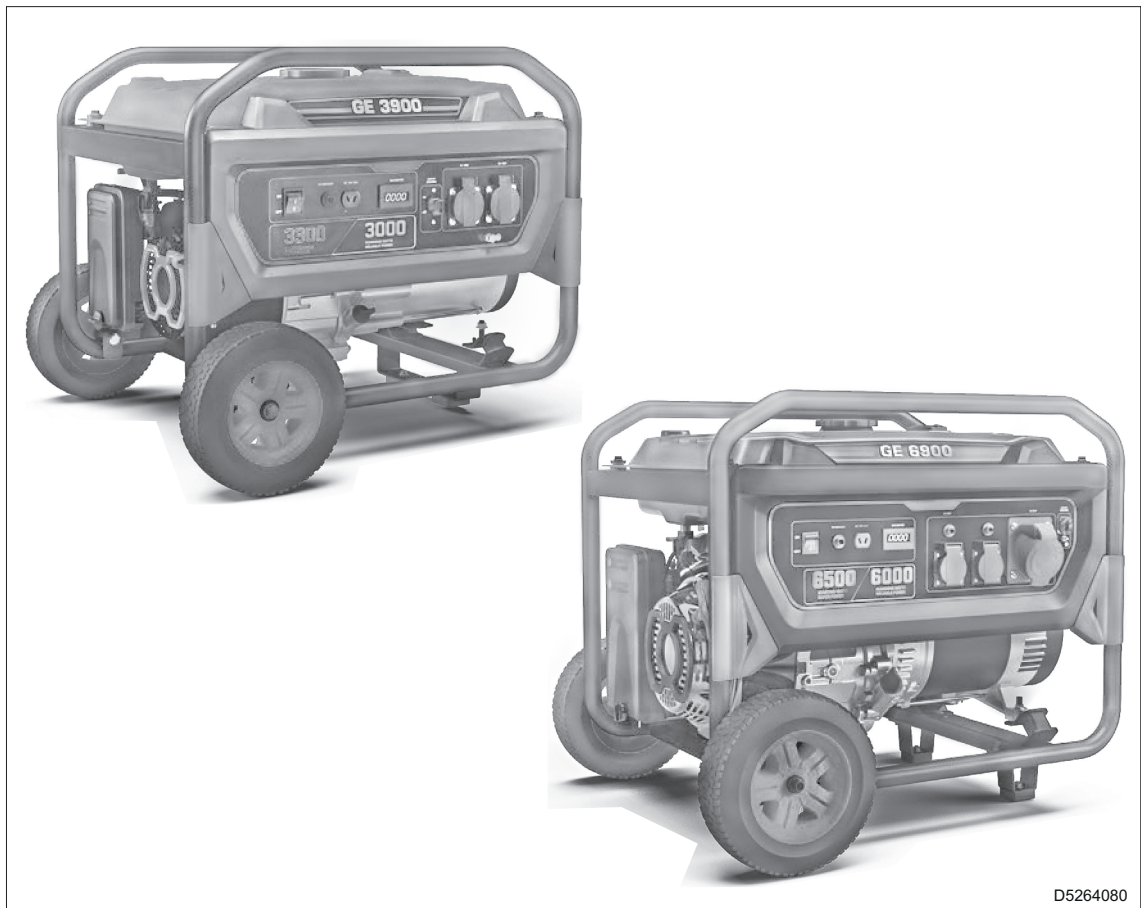

D5264080

Generating set GE 3900 GE 6900



Original instructions

Contents

1.	Introduction.....	1
1.1	Foreword	1
1.2	Supplied documentation	1
1.3	Customer service.....	2
1.4	Spare parts	2
1.5	Declaration of conformity.....	2
1.6	Unauthorized changes.....	2
1.7	Allowed and non-allowed use.....	2
1.8	Identification data	3
2.	Safety.....	5
2.1	Safety information.....	5
2.2	Positioning of safety decal and information	6
	2.2.1 Decal explanation	7
2.3	General precautions	9
	2.3.1 Personal protective equipment.....	9
	2.3.2 Check the work area.....	9
2.4	Fire prevention.....	10
	2.4.1 Fire due to fuel, oil.....	10
	2.4.2 Fires caused by flammable material build-up	10
	2.4.3 Fire caused by electrical wiring	10
	2.4.4 Fire caused by piping	10
2.5	Lifting and transport precautions	11
	2.5.1 Lifting by chains or ropes.....	11
	2.5.2 Lifting and manual transport (Mod. GE 3900)	11
	2.5.3 Transport with towing carriage.....	11
2.6	Precautions for positioning the machine.....	12
	2.6.1 Positioning site precautions.....	12
	2.6.2 Precautions for electric connections.....	12
2.7	Precautions during operation.....	12
2.8	Precautions against noise	13
2.9	Precautions during fuel and engine oil filling	13
2.10	Maintenance precautions	13
2.11	Precautions for disposal of waste material	14
2.12	Disposal of the machine	14
3.	Technical data.....	15
3.1	Machine dimensions.....	15
3.2	Technical data (mod. GE 3900).....	16
3.3	Technical data (mod. GE 6900).....	17
3.4	Electrical diagram	18
4.	Description.....	19
4.1	Main components of GE 3900	19
4.2	Main components of GE 6900	20
5.	Delivery, unpacking and installation	21

5.1	Delivery.....	21
5.2	Unpacking.....	21
6.	Operation.....	23
6.1	Operating conditions.....	23
6.1.1	Power	23
6.1.2	Voltage.....	23
6.1.3	Frequency.....	23
6.2	Grounding.....	24
6.3	Checks before start-up	25
6.4	Starting and stopping the engine.....	25
6.4.1	Starting the engine	25
7.	Maintenance.....	29
7.1	Ordinary Maintenance Schedule	29
7.2	Fuel.....	30
7.3	Engine oil.....	30
7.3.1	Refuelling and checks	30
7.3.2	Replacement	31
7.4	Engine air filter.....	31
7.4.1	Check and clean.....	31
7.4.2	Replacement	32
7.5	Cleaning the carburetor tank	32
7.6	Checking and replacing the spark plug	32
7.7	Storage.....	33
7.8	Disposal.....	33

1. Introduction

1.1 Foreword

This manual supplies the Operator and qualified and authorised Technicians with technical information on the GE 3900 and GE 6900 generating sets (hereinafter also referred to as the "machine") produced by MOSA Div. of BCS S.p.A. (hereinafter also referred to as the "manufacturer").

In this manual, the Operator in charge and the qualified Technicians will find the indications for:

- Getting familiar with the safety measures and basic standards to be adopted, to prevent hazards and damage to people, to the machine and to the environment.
- Getting to know the main components of the machine and its operation.
- Performing the programmed routine maintenance.
- Getting to know any extraordinary maintenance operation.

This manual is an integral part of the machine and must follow it in any changes of ownership, until the final dismantling.

The manual and all the publications attached to it must be kept with care, in an easily accessible place, known to the operator and to the qualified technicians authorized for maintenance. Read the descriptions carefully before starting to work or carrying out the required adjustments or maintenance.

If the manual is lost, damaged or becomes illegible, request a copy to MOSA, indicating the model of the machine, the serial number and the year of construction.

If the machine is transferred, the transferor must deliver this manual to the new owner.

The machine is subject to updates to improve its performance; this manual summarises the information regarding the current state of technology at the moment of the supply.

MOSA reserves the right to make improvements and modifications to parts and accessories, without promptly updating this manual, except in exceptional cases of fundamental integrations concerning safe operation.



CAUTION

- **Improper use or maintenance can cause serious damage to people and shorten the "useful life" of the machine.**
- **The Operator and the qualified Technicians must be familiar with all the indications given in this manual before using the machine or carrying out maintenance operations on it.**
- **The procedures contained in this manual are intended to be applicable to machine only for permitted uses, and with all safety devices in function.**
If the machine is used for purposes other than those indicated or in safety conditions other than those indicated, the Customer becomes directly responsible for any person possibly involved in accidents or injuries and for abnormal wear and tear of the machine.

1.2 Supplied documentation

The documents supplied with the machine include this Use and Maintenance Manual.

1.3 Customer service

The Technical Assistance and Spare Parts Service are available to the Customers.

MOSA recommends that you contact the nearest authorised service centre for specialised intervention for all control and overhaul operations.

In order to obtain quick and effective responses, indicate the Model and Serial Number shown on the identification plate (see “1.8 Identification data”).

1.4 Spare parts

Only original spare parts that guarantee functionality and durability must be used.

The use of non-original spare parts will void all warranty and Technical Support obligations.

1.5 Declaration of conformity

The manufacturer:

MOSA Div. of BCS S.p.A.

Viale Europa, 59 20047 Cusago (Milano) Italy

Declares that the machines:

GE 3900

GE 6900

Comply with the requirements of the following EC/EU Directives:

- Machine Directive 2006/42/EC
- Low Voltage Directive 2014/35/EU
- Electromagnetic Compatibility Directive 2014/30/EU

and with the requirements of the following UK regulations:

- The Supply of Machinery (Safety) Regulations 2008/1597
- The Electrical Equipment (Safety) - Regulations 2016/1101
- Electromagnetic Compatibility - Regulations 2016/1091

1.6 Unauthorized changes

No changes can be made to the machine without MOSA'S authorization.

Unauthorized changes void any form of warranty on the machine and any civil and/or criminal liability in case of accidents or injuries

1.7 Allowed and non-allowed use

This generating set is used to generate electrical current in accordance with the specifications of the declared electrical system.

1.8 Identification data

The data identifying the machine are specified on the ID plate applied in the area indicated in the figure. They are necessary for spare parts requests and communications with the Customer Service Department.



CXXXXX (Serial N./Matricola) B

A			Low-power generating set		
B	Model:		EN ISO 8528-13		
C	Rated Power	kW	Rated Voltage	V	Quality Class
	Maximum Power	kW	Rated Current	A	Performance Class
	Rated Frequency	Hz	Mass Weight	kg	Power Factor
A	IP Grade	IP23M		Year of manufacture	B
A	BCS S.p.A. Viale Europa 59 - 20090 Cusago (MI) ITALY - www.mosa.it				

D5264090

A - Manufacturer 's data

B - Machine data

- *Model:* model
- Reference technical standard
- *Year of manufacture:* Year of manufacture
- *Serial No.:* Machine Serial Number

C - Machine technical data

- *Rated Power:* Rated power - kW
- *Maximum Power:* Maximum Power - kW
- *Rated Frequency:* Rated frequency Hz
- *IP Grade:* IP protection degree
- *Rated Voltage:* Rated voltage - V
- *Rated Current:* Rated current - A
- *Mass Weight:* Dry weight (kg)
- *Quality Class:* Quality class - Output
- *Performance Class:* Performance class - Output
- *Power Factor:* Rated cosφ (power factor)

2. Safety

2.1 Safety information

Always respect the warnings contained in this manual and present on the decal applied to the machine. This allows the machine to be used safely, avoiding damage to property and injury or death to people. The following words and symbols were used to identify important safety messages.

Symbol  identifies important safety messages on the machine, in the manual and elsewhere. When you see this symbol, follow the instructions in the safety messages.

DANGER

- This word indicates a situation of imminent risk that, if not avoided, could cause serious injury or even death to people and serious damage to property.

WARNING

- This word indicates a potential risk situation which, if not avoided, could result in serious injury or even death to people and serious damage to property.

CAUTION

- This word indicates a potential risk situation that, if not avoided, could cause minor or moderate injuries.
It can also be used to prevent dangerous operations that can cause damage to the machine.

The following terms are used to transmit the information to be followed to the user, to avoid damage to the machine.

Important

- If the precautions described are not observed, the machine could be damaged and its useful life reduced.

Note:

- This word is used to indicate further useful information.

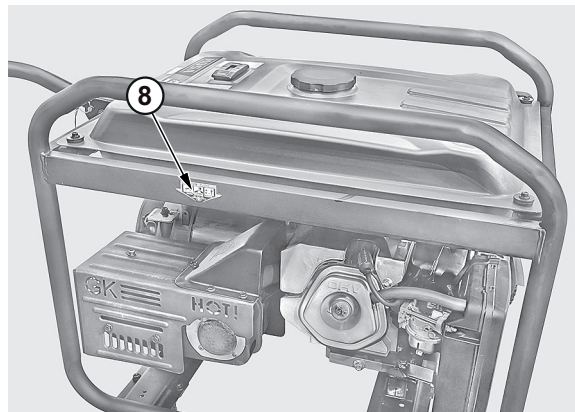
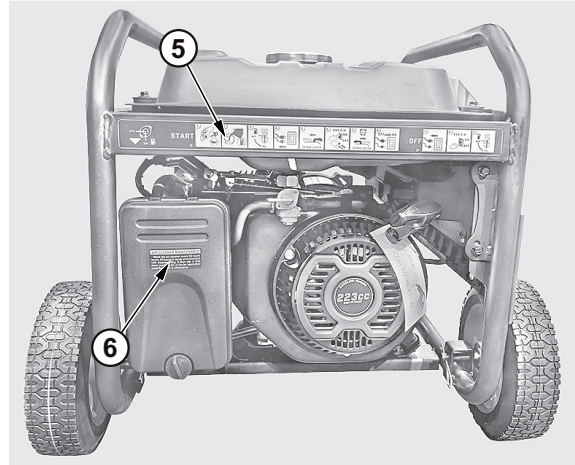
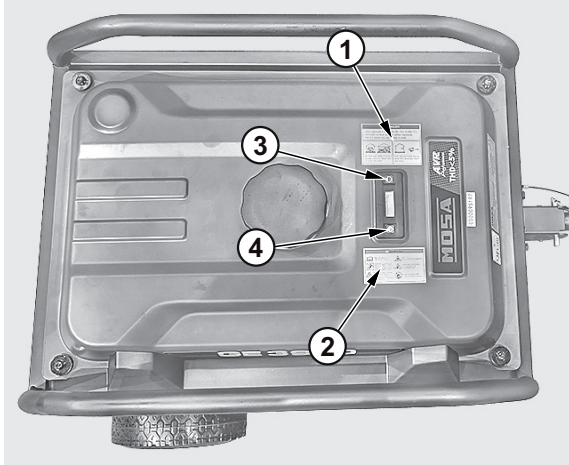

2.2 Positioning of safety decal and information



D5264140

2.2.1 Decal explanation

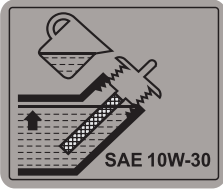
<p style="text-align: right;">G8815G0502000</p>	<ul style="list-style-type: none"> • Pos. 1 - Danger! Using the generator set inside a building could be fatal. The exhaust gases from the generator set contain carbon monoxide, a colourless and odourless poison. Do not use the generator set inside a building even if windows and doors are kept open. Use the generator set outdoors in a ventilated place away from doors and windows.
<p style="text-align: right;">G8820G0502000</p>	<ul style="list-style-type: none"> • Pos. 2 -Warning Consult the manual The following dangers may arise during use and maintenance. <ul style="list-style-type: none"> ◦ Danger of electric shock. Do not install the machine in damp areas and do not expose it to rain or snow. Do not handle the machine with wet hands or feet. ◦ Risk of electrocution. Ground the generator set. ◦ Danger of fire. Do not refuel while the machine is running. ◦ Danger of inhaling toxic gases. Use the machine in a ventilated place. ◦ Do not expose electrical sockets to rain or moisture.
<p style="text-align: center;">G8806G0102000 G8806G0101000</p>	<ul style="list-style-type: none"> • Pos. 3 - Maximum fuel level • Pos. 4 - Low fuel level (on reserve)
<p style="text-align: right;">G8821G0508000</p>	<ul style="list-style-type: none"> • Pos. 5 - Starting and stopping procedure.
<p style="text-align: right;">G8802E0103010</p>	<ul style="list-style-type: none"> • Pos. 6 - Air filter maintenance. Clean the air filter every 50 hours (every 10 hours in case of dusty environments) and dry it. Immerse it in clean oil. Wipe off any excess oil.

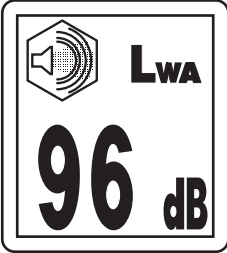
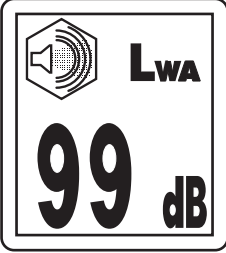
 <p>SAE 10W-30</p> <p>G8806E0102000</p>	<ul style="list-style-type: none"> • Pos. 7 - Access plug for engine oil control, top-up and replacement.
 <p>G8812G0101000</p>	<ul style="list-style-type: none"> • Pos. 8 - Warning Risk of burns. Risk of inhaling toxic gases Keep a safe distance from and do not touch hot surfaces.
<div style="display: flex; justify-content: space-around;"> <div style="text-align: center;"> <p>GE 3900</p>  </div> <div style="text-align: center;"> <p>GE 6900</p>  </div> </div> <p>D5264100</p>	<ul style="list-style-type: none"> • Pos. 9 - Sound power level Unit of measurement dB(A); represents the amount of acoustic energy emitted in the unit of time, regardless of the distance of the measuring point.

2.3 General precautions

Any errors during use, checks or maintenance could cause the risk of injury, even serious

- Before performing the operations, read this manual and the decals applied to the machine and follow the warnings.
If you don't understand any part of the manual, ask your Safety Officer for explanations.
- The machine can only be used and repaired by trained and authorized personnel.
- Do not work if you feel unwell, have drunk alcohol or take medicines that impair your ability to work safely or repair the machine.
- Before starting the operations, check the machine. If anomalies are detected, do not operate on the machine before having completed the necessary repairs.
- Comply with the provisions and laws in force in the country in which you work.

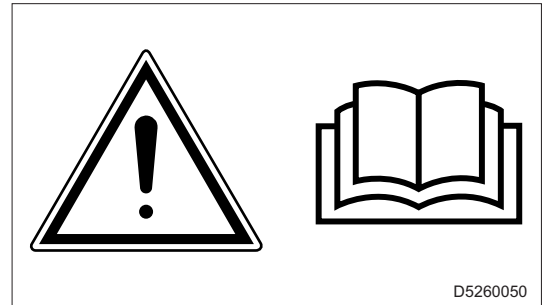

2.3.1 Personal protective equipment

- Do not wear clothes that are too loose or accessories, to prevent them from becoming entangled, causing personal injury.
- Always wear the personal protective equipment prescribed for the place where you work, such as a protective helmet, safety footwear, safety glasses, gloves and noise protection headphones.
- Before using personal protective equipment, check that it is in perfect condition.



2.3.2 Check the work area

- Ask the site safety manager for information on the regulations to be observed.
- Understand the signs and indications on site.
- Make sure that fire extinguishers and first aid kit are available on site and inquire about where they are located.
- Check that the area is clear of materials that may be hazardous during the operation of the generating set (such as flammable materials or liquids).
- Make sure that there are no unauthorized persons in the area.

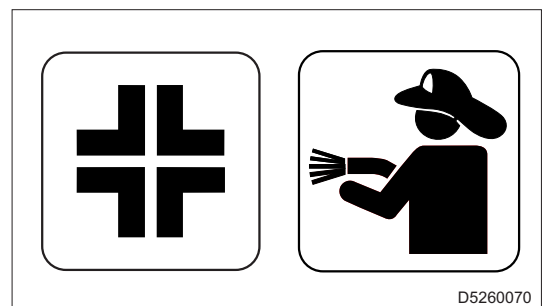

2.4 Fire prevention

2.4.1 Fire due to fuel, oil

- Avoid approaching any flame to flammable substances such as fuel and oil.
- Do not smoke or use open flames near flammable substances.
- Stop the machine before refuelling.
- Make sure not to spill flammable substances on overheated surfaces or on parts of the electrical system.
- After refuelling, remove any spills and tighten all filling caps tightly.
- For safety in the workplace, store the cloths soaked in flammable materials in a container.
- Store oil and fuel in pre-established and well-ventilated locations and prohibit the entry of unauthorised personnel.
- When cleaning the machine, do not use flammable substances such as diesel or gasoline.



2.4.2 Fires caused by flammable material build-up

- Remove dry leaves, chips, pieces of paper, carbon dust, or other flammable materials accumulated from the machine.

2.4.3 Fire caused by electrical wiring

- Always keep the electrical wiring clean and tightened.
- Periodically check that there are no loose or damaged parts. Tighten loose wiring connectors or terminals.
- Repair or replace any damaged cables.

2.4.4 Fire caused by piping

- Periodically check that the hose clamps are firmly fixed.
- If loosened, they may vibrate during machine operation and cause leakage of liquids, provoking fires and serious injuries, including fatalities.

2.5 Lifting and transport precautions

2.5.1 Lifting by chains or ropes

- Make sure that the handling area is clear of obstacles and people.
- Handle the machine with the engine off, the electrical cables disconnected and the fuel tank empty.
- Lift the machine only by the frame.
- Check the condition of the frame. If it is damaged, replace it before lifting the machine.
- Always use lifting equipment adequately sized and controlled by authorized bodies.
- Do not harness the machine with a single rope. Use two ropes placed symmetrically to keep the machine in a horizontal position.
- Do not subject the machine and the lifting equipment used to undulating or abrupt movements that transmit dynamic stresses to the structure.
- Do not lift the machine at a height higher than that necessary for handling.
- Do not leave the machine suspended for longer than necessary for handling.



2.5.2 Lifting and manual transport (Mod. GE 3900)

- The machine should be lifted and transported by at least 2 people.
- Handle the machine with the engine off, the electrical cables disconnected and the fuel tank empty.

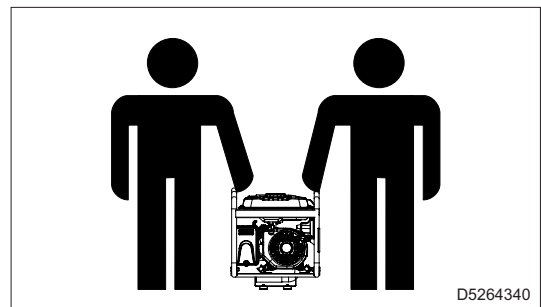

2.5.3 Transport with towing carriage

- The machine is equipped with a towing carriage for easy handling, which is to be assembled according to the instructions that are included in the packaging.
- Handle the machine with the engine off, the electrical cables disconnected and the fuel tank empty.

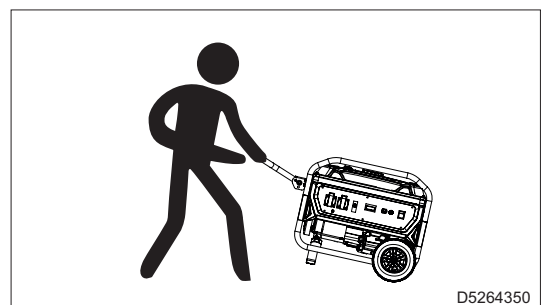

2.6 Precautions for positioning the machine

2.6.1 Positioning site precautions

- The machine may not be used indoors, such as in homes and garages, even if the doors and windows are open.
This machine has been designed for outdoor use and can therefore be positioned outdoors.
In case of meteorological precipitation (rain, snow, etc.), place the machine in an adequately sheltered place. If this is not possible, do not use the machine.
- Do not place machines or equipment near heat sources, in areas at risk with explosion hazard or fire hazard.
Place the machine at a safe distance from fuel tanks, from flammable material (rags, paper, etc.), from chemicals.
Follow the instructions of the competent authorities.
- To limit potentially dangerous situations, isolate the area around the machine, thus preventing any unauthorized personnel from getting close to it.
- Although the machines produced comply with the regulations on electromagnetic compatibility, do not place the machine near equipment influenced by the presence of magnetic fields.
- Make sure that the area immediately surrounding the machine is clean and free of debris.
- Always place the machine on a flat, solid surface that is not subject to failure in order to avoid tipping, slipping or falling during operation.
- The machine must always be positioned so that exhaust gases disperse into the air without being inhaled by people or animals.
The exhaust gases of an engine contain carbon monoxide: this substance is harmful to health and, in high concentration, can cause poisoning and death.
- If the machine is used indoors, make sure that the area is well ventilated.

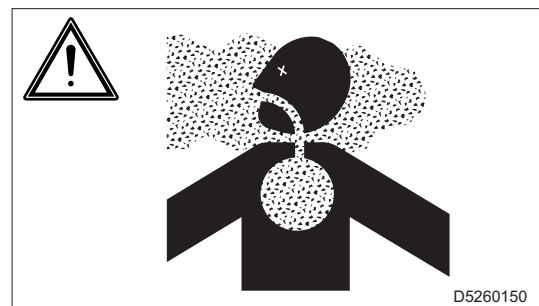

2.6.2 Precautions for electric connections

- Use appropriate electrical plugs at the machine output sockets and make sure that the electrical cables are in good condition.
- Do not use the machine with wet or damp hands and/or clothing.

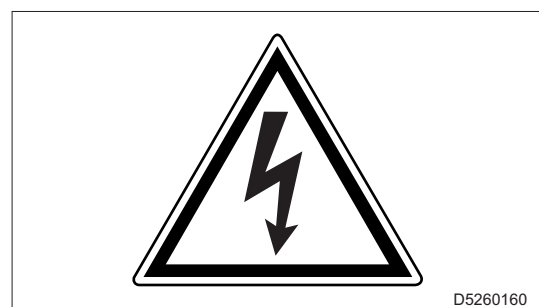

2.7 Precautions during operation

- Keep all panels closed during normal operation.
- Access to the internal parts of the machine must only be carried out for maintenance purposes.
- Keep the area near the muffler free from objects such as rags, paper, cartons.
The high temperature of the muffler could cause the objects to burn and cause a fire.
- Immediately stop the machine in case of malfunctions.
Do not restart the machine without first identifying and solving the problem.
- Do not wrap or cover the machine with cloths while it is running.
Before covering the machine, make sure that the engine parts are cold

2. Safety

If the engine parts are still warm, there is a risk of damage to the machine and fire.

- Do not place objects or obstacles near the air suction and expulsion windows; a possible overheating of the machine could cause a fire.

2.8 Precautions against noise

- Excessive noise can cause temporary or permanent hearing problems. The actual risk arising from the use of the machine depends on its use conditions.
- There is a decal on the machine that declares the sound power level dB(A) emitted by it. The value provides an indication of the noise level emitted by the machine when used, in order to assess the noise in the environment where the generator is placed.
- The adoption of specific measures (such as headphones or earplugs) must be assessed by the operator.

2.9 Precautions during fuel and engine oil filling

- Fuel and engine oil are flammable. Refill with the engine off.
- Refuel only outdoors or in well-ventilated environments.
- Do not smoke or use naked flames during refuelling.
- Do not fuel with the engine running or hot.
- Clean and dry any leaks of engine oil and fuel before restarting the machine.
- After refuelling, fully tighten the tank caps.
- Do not fill the fuel tank completely to allow expansion of the fuel inside it.
- Do not exceed the MAXIMUM engine oil level.



2.10 Maintenance precautions

- Stop the machine and disconnect all electrical devices.
- To avoid injury, do not perform maintenance with the engine running.
 - Rotating parts, such as the fan, are dangerous and can get entangled on body parts or a worn object. When performing maintenance, be careful to approach rotating parts.
 - Make sure not to drop or insert tools or other objects in the fan or other rotating parts. They can touch the rotating parts and be projected.



- Do not touch the engine, pipes and muffler during operation or immediately after shut-off. Allow the engine to cool before performing any operation.
- When discharging the engine oil, the engine must be hot. Engine oil may come into contact with the skin and cause burns.
- Do not remove the guards and safety devices. If it is necessary to remove them, after completing the maintenance, install the removed guards and restore the safety devices.
- Use work tools in good condition and suitable for the work to be performed. If you use a damaged or deformed tool or if you use a tool for a purpose other than its intended purpose, there is a danger of causing serious personal injury or death.
- Be careful not to damage the electric starter battery, as it contains lithium. If lithium leaks out and comes in contact with oxygen in the air, it can catch fire causing an explosion.

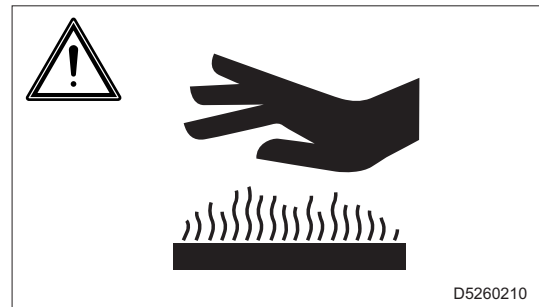

2.11 Precautions for disposal of waste material

- Be sure to store the waste liquid in containers or tanks.
- Do not discharge the oil directly into the soil or sewage system, rivers, seas or lakes.
- When disposing of harmful waste such as oil, fuel, coolant, solvents, filters and batteries, follow current laws and regulations.
- Entrust the authorized companies with the disposal of rubber material, plastic and components that contain them (hoses, cables, wiring, etc.) in accordance with the applicable laws and regulations.

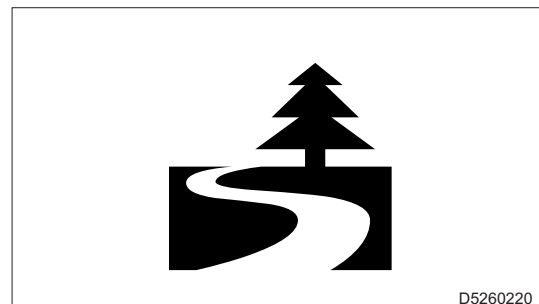

2.12 Disposal of the machine

This machine is classified as Electrical Equipment. For disposal, comply with *Directive 2012/19/EU* on waste of electric and electronic equipment (WEEE). The symbol affixed to the product or to the documentation states that, at the end of its useful life, the machine must be disposed of separately. Adequate separate collection helps avoid possible negative effects on the environment and health and promotes the reuse and/or recycling of the materials that make up the equipment.

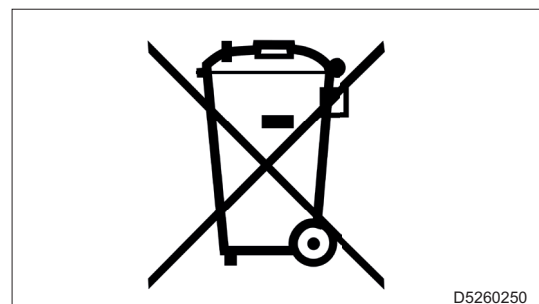

3. Technical data

3.1 Machine dimensions

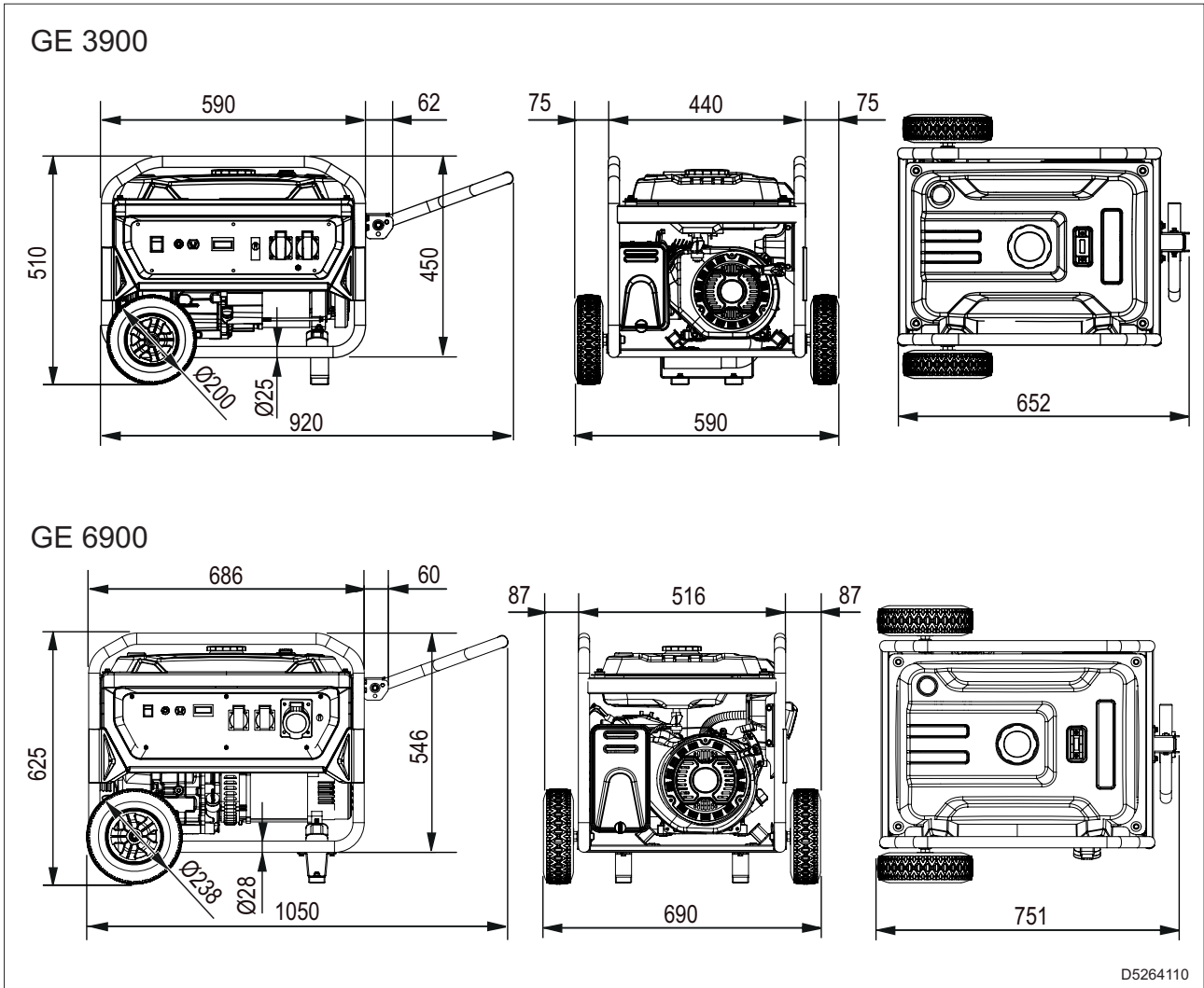

3.2 Technical data (mod. GE 3900)

Rated output powers

* Single-phase stand-by power (LTP)	3.3 kVA/kW / 230V / 14.3A
* Single-phase PRP power	3 kVA/kW / 230V / 13A
Frequency	50 Hz
Cos φ	1

* Declared powers according to ISO 8528

Note

- The declared powers are valid at a temperature of 25 °C and an altitude of 100 metres above sea level
- **Stand-by power (LTP):** emergency power. Maximum power available for use with variable loads for a number of hours/year limited to 500h. Overloading is not allowed.
- **PRP power:** continuous power with variable loads. Prime power available for use at constant load for an unlimited number of hours/year. The average power that can be drawn over a 24-hour period must not exceed 70% of the PRP.

Alternator

Continuous power	3 kVA
Stand-by power	3.3 kVA
Single-phase voltage	230 Vac
Frequency	50 Hz
Insulation	Class H
Harmonic distortion - THD	< 5 %

Engine

Model	GK 225
Engine type	Single-cylinder, 4-stroke, air-cooled, OHV
Displacement	1 / 223 cm ³ (0.223 l)
Fuel	Gasoline fuel
Compression ratio	8,7:1
Engine oil quantity	0.55 l

General specifications

Fuel tank capacity	15 l
Autonomy (50% PRP)	9 h
Autonomy (100% PRP)	6.5 h
IP protection degree	IP 23M
LwA Acoustic power (LpA sound pressure)	96 dB(A) (71 dB(A) @ 7m)
Performance class	G1
Weight (Dry)	45 kg

3.3 Technical data (mod. GE 6900)

Rated output powers

* Single-phase stand-by power (LTP)	6.5 kVA/kW / 230V / 28.3A
* Single-phase PRP power	6 kVA/kW / 230V / 26A
Frequency	50 Hz
Cos φ	1

* Declared powers according to ISO 8528

Note

- The declared powers are valid at a temperature of 25 °C and an altitude of 100 metres above sea level
- **Stand-by power (LTP):** emergency power. Maximum power available for use with variable loads for a number of hours/year limited to 500h. Overloading is not allowed.
- **PRP power:** continuous power with variable loads. Prime power available for use at constant load for an unlimited number of hours/year. The average power that can be drawn over a 24-hour period must not exceed 70% of the PRP.

Alternator

Continuous power	6 kVA
Stand-by power	6.6 kVA
Single-phase voltage	230 Vac
Frequency	50 Hz
Insulation	Class H
Harmonic distortion - THD	< 5 %

Engine

Model	GK 420
Engine type	Single-cylinder, 4-stroke, air-cooled, OHV
Displacement	1 / 420 cm ³ (0.42 l)
Fuel	Gasoline fuel
Engine oil quantity	1.1 l

General specifications

Fuel tank capacity	20 l
Autonomy (50% PRP)	8 h
Autonomy (100% PRP)	6.5 h
IP protection degree	IP 23M
LwA Acoustic power (LpA sound pressure)	99 dB(A) (74 dB(A) @ 7m)
Performance class	G1
Weight (Dry)	88 kg

3.4 Electrical diagram

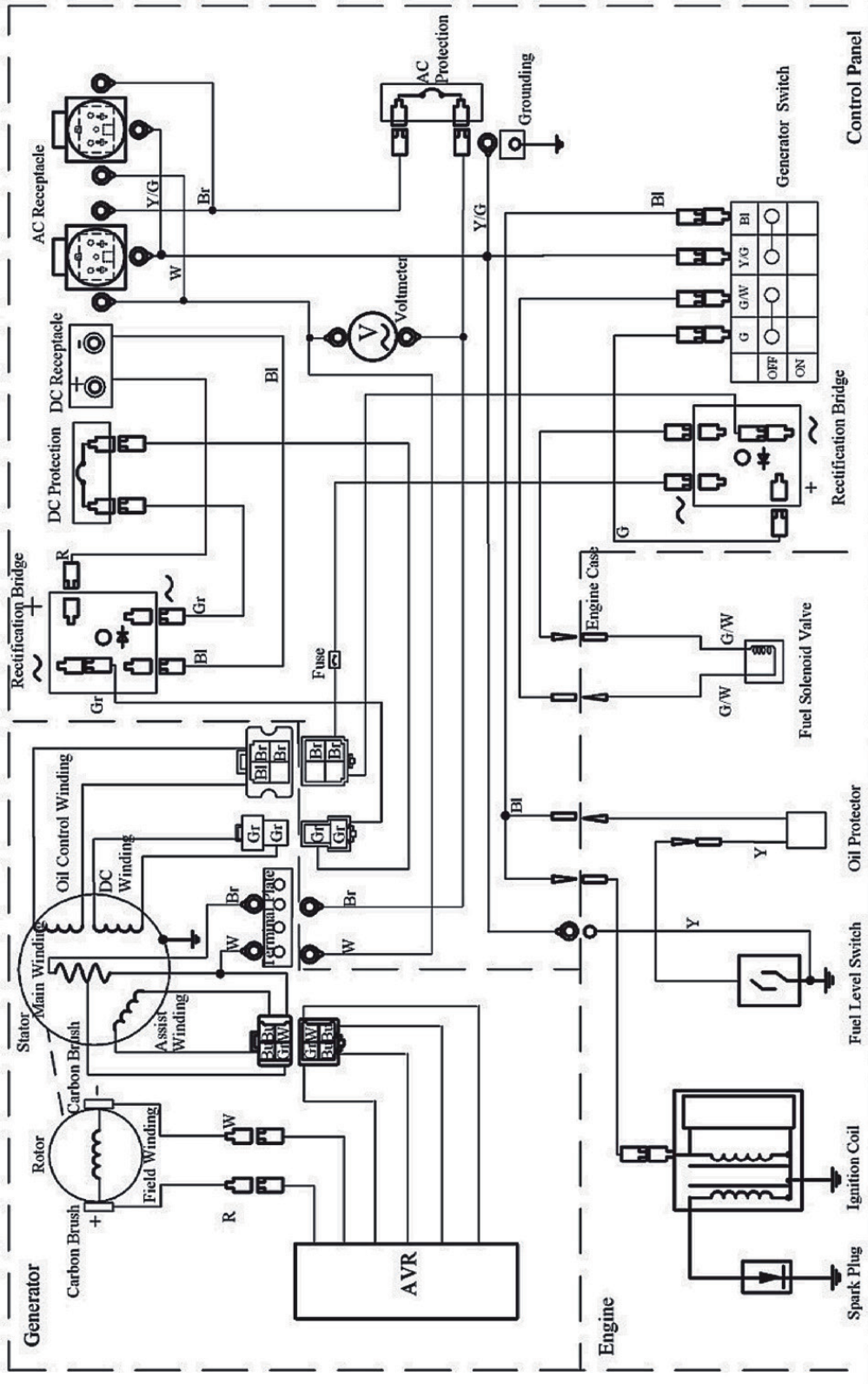

Bl	Black	R	Red
Y	Yellow	W	White
Bu	Blue	Br	Brown
G	Green	Gr	Grey

This figure is for reference only

4. Description

The Generating Set is a machine that transforms mechanical energy, generated by an engine, into electrical energy through an alternator.

4.1 Main components of GE 3900

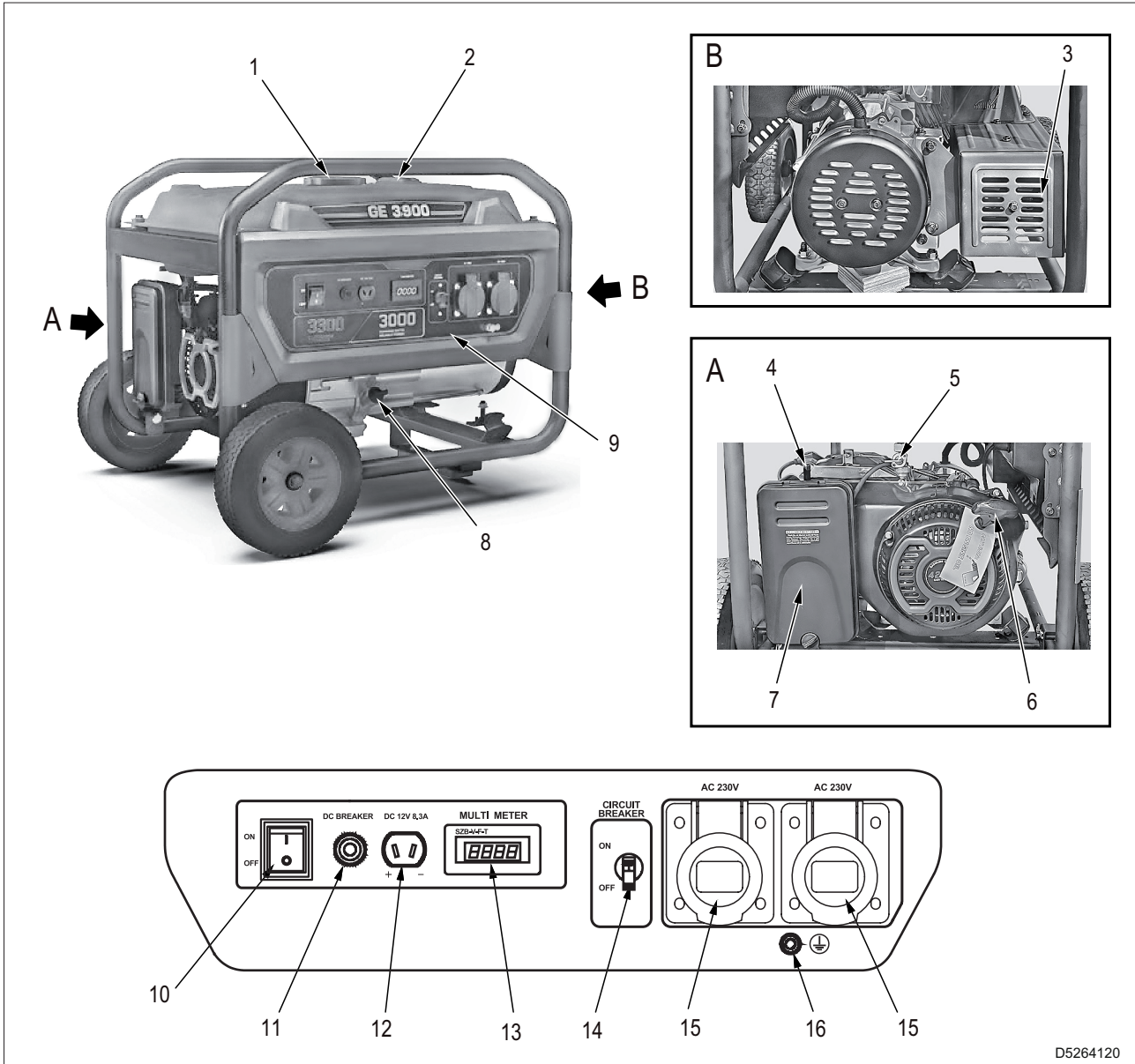

D5264120

- | | |
|---|--|
| <ul style="list-style-type: none"> 1 - Tank cap 2 - Fuel level indicator 3 - Muffler 4 - Choke control lever 5 - Fuel valve 6 - Pull start 7 - Air filter 8 - Oil filler plug 9 - Control panel 10 - Engine start and stop switch | <ul style="list-style-type: none"> 11 - Thermal circuit breaker for 12VDC output protection 12 - 12 VDC output (battery charger) 13 - Multi-purpose digital instrument 14 - Main machine switch 15 - 230V 16A 2P+T Schuko socket (No. 2) 16 - PE ground terminal |
|---|--|

4.2 Main components of GE 6900

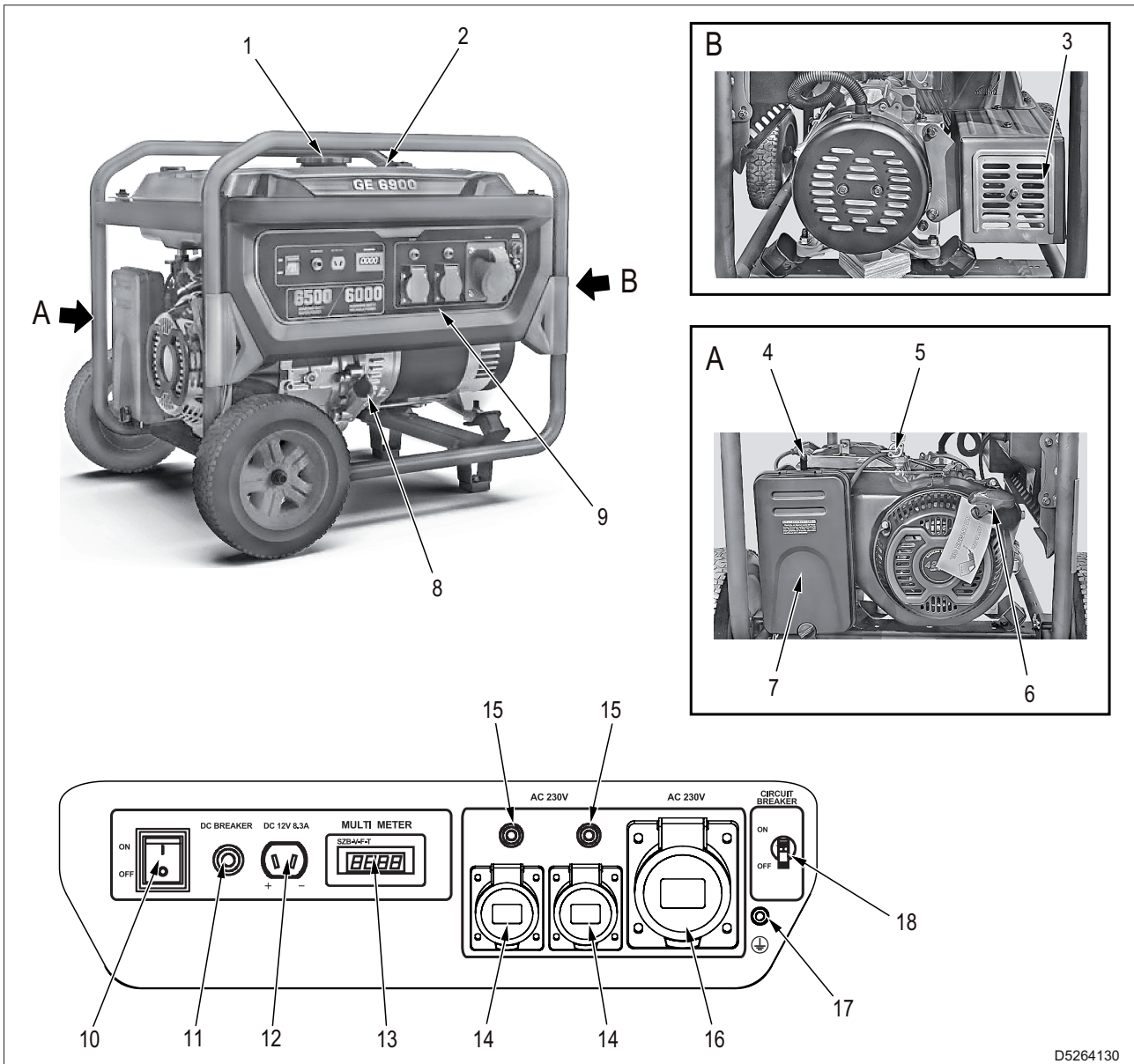

- 1 - Tank cap
- 2 - Fuel level indicator
- 3 - Muffler
- 4 - Choke control lever
- 5 - Fuel valve
- 6 - Pull start
- 7 - Air filter
- 8 - Oil filler plug
- 9 - Control panel
- 10 - Engine start and stop switch

- 11 - Thermal circuit breaker for 12VDC output protection
- 12 - 12 VDC output (battery charger)
- 13 - Multi-purpose digital instrument
- 14 - 230V 16A 2P+T Schuko socket (No. 2)
- 15 - Thermal Protection
- 16 - 230V 32A 2P+T CEE socket
- 17 - PE ground terminal
- 18 - Main machine switch

D5264130

5. Delivery, unpacking and installation

5.1 Delivery

- The machine is normally transported and delivered packed in a suitable cardboard box.
- All shipped equipment is checked before being delivered to the Client.
- Check the material delivered against the detailed shipment list.

Important

- Upon receipt, check the equipment for damage (breakage or significant dents) caused by transport. If this occurs, immediately inform the transport company and write down the "Conditional Acceptance" clause in the delivery note.
- In the event that, at the time of delivery, significant damage is found, caused during transport, together with any missing parts that may be found, promptly notify MOSA Div. of BCS S.p.A.

5.2 Unpacking

- Unloading of the packaging must be carried out with the utmost care, using lifting equipment of a suitable capacity (e.g. forklift truck), if necessary.
- Place the packaging on a stable and horizontal surface.
- Load handling operations must be carried out by qualified personnel, in compliance with the current regulations on safety in the workplace of the country of use.



Do not dump the packaging into the environment; comply with the regulations in force in the country of use.

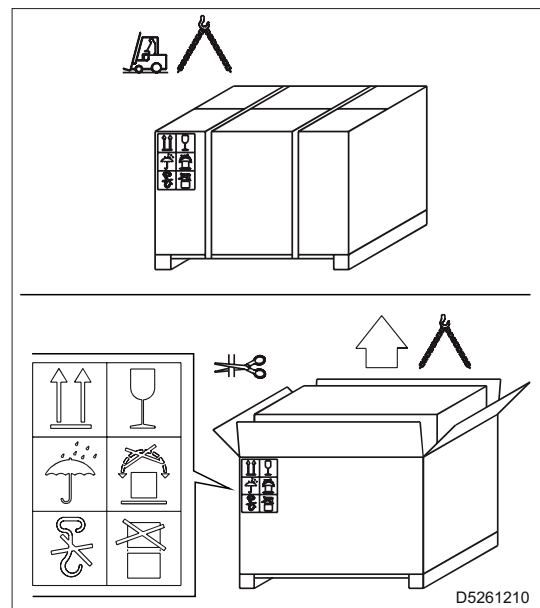

- 1 - Remove the machine (1) and the documents (2) from the packaging.

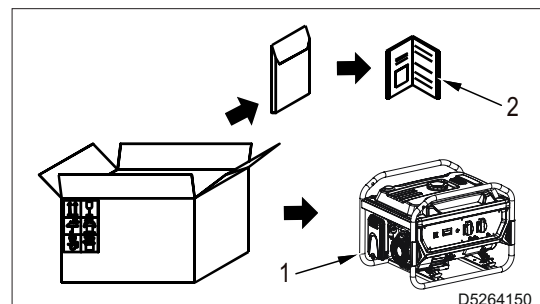

2 - Check the machine identification plate, the integrity of the decal and data, and read the use and maintenance manual before proceeding with use.

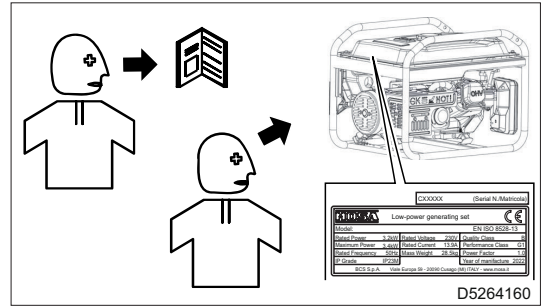

6. Operation



WARNING

- Before positioning and starting the machine, read section “2. Safety” carefully.
- Do not overload the generator because it may get damaged.

6.1 Operating conditions

6.1.1 Power

The electrical power of the generating set, expressed in kVA, is the available output power at the reference environmental conditions and at the rated values of: voltage, frequency, power factor ($\cos \phi$).

There are different types of power established by ISO 8528-1 and 3046/1:

- PRIME POWER (PRP)
- STAND-BY POWER
- COP

See “3. Technical data”.



Important

- When using the generating set, do not exceed the declared powers, paying particular attention when powering multiple loads at the same time.

6.1.2 Voltage

Alternators with Electronic Adjustment (AVR)

In these types of generating sets, the voltage accuracy is maintained within $\pm 1.5\%$ with speed variation between -10% and $+30\%$.

The voltage remains constant both with no load and with loads connected.

The insertion and release of the load causes a change of transient voltage lower than 15% , with return to the rated value within $0.2-0.3$ seconds.

6.1.3 Frequency

Frequency is a parameter directly dependent on engine revolutions.

With a 2-pole alternator, you have a frequency of $50/60$ Hz with a rotational speed of $3000/3600$ rpm.

The generating set engine is equipped with a mechanical speed regulator.

The mechanical speed regulator has an idle to full load speed droop of less than 5% , while under static conditions, the accuracy is maintained within $\pm 1\%$.

- For 50Hz generators, the no-load frequency is $52-52.5$ Hz
- For 60Hz generators, the no-load frequency is $62.5-63$ Hz.
- The nominal frequency of 50Hz or 60Hz is reached at the maximum output power (kW) of the generating set

Power factor - $\cos \phi$

The power factor is a data that depends on the electrical characteristics of the load.

The use of electrical equipment with a different $\cos \phi$ will reduce the power output of the generator.

For information on power reduction, contact the Technical Support Service.

Asynchronous motor start

Starting an asynchronous motor by a generating set can be critical, due to the high starting currents that the asynchronous motor requires (I_{avv.} = up to 8 times rated current I_{n.}).

The starting current must not exceed the overload current allowed by the alternator for short periods, generally 250-300% for 10-15 seconds.

To avoid oversizing the group, we recommend adopting some precautions:

- When starting multiple motors, divide them into groups and arrange for them to start at intervals of 30-60 seconds.
- If the machine coupled to the motor allows it, set it for a reduced-voltage start, star/triangle start or with autotransformer, or use a soft-start system.

In all cases, when the user circuit provides for the start of an asynchronous motor, it is necessary to check that there are no utilities inserted in the system that, due to the transient voltage drop, may cause more or less serious disruptions (opening of contactors, temporary power failure to command and control systems, etc.).

6.2 Grounding



WARNING

- **The machine is not equipped with a residual current circuit breaker, and must not be connected to a grounding system.**

- Protection against electric shock from indirect contacts is ensured by the "electrical separation" protection, with equipotential connection between all the masses of the machine.
- The limitation of the electrical circuit extension is essential for safety purposes; do not power systems with a length greater than 200 meters.
- The power cables of the equipment must be equipped with the protective conductor (yellow-green cable) to ensure the equipotential connection between the mass of the equipment and the mass of the machine; this provision is not valid for double insulated or reinforced insulated equipment recognizable by the symbol .
- The cables must be suitable for the environment in which they are operated.
In case of temperatures below 5°C, PVC cables become rigid and the PVC insulation tends to be cut at the first fold.

- Electrical separation protection is not suitable if the machine is intended to power complex systems, or located in particular environments with a higher risk of electric shock.

In these cases, it is necessary to adopt the electrical safety measures required by current regulations.

Example:

It is possible to install a high sensitivity, 30mA, residual current circuit breaker and ground the machine Neutral. This operation must be performed by a qualified electrician or at an authorised service centre.

In this case, machine grounding is mandatory to ensure protection against indirect contacts by the residual current circuit breaker.

Connect the machine to a grounding system via a cable using the grounding terminal (1).

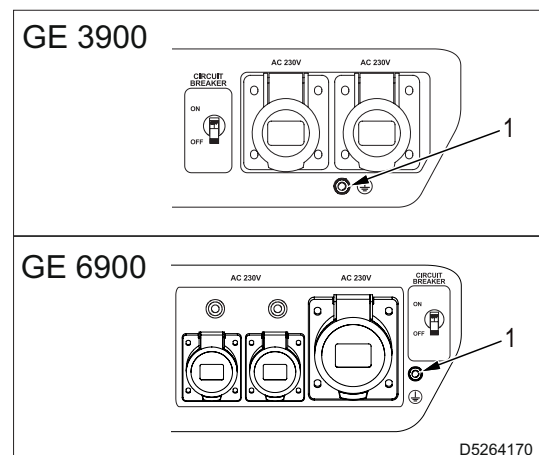

D5264170

6.3 Checks before start-up

WARNING

- The machine is shipped without engine oil. Before starting the machine, fill it with oil. For the details, see “7. Maintenance”.

- 1 - Check the oil and fuel levels. For details, see “7.2 Fuel” and “7.3 Engine oil”.
- 2 - Check that there are no oil and fuel leaks.
- 3 - Check that there is no flammable or dirty material around the machine.
- 4 - Check that there are no unauthorized persons in the area adjacent to the machine.
- 5 - Check that the connection cables between the generator and the user system comply with the rated voltages of the system.
The type of cable, section and length must be sized according to the environmental conditions of installation and local regulations.
- 6 - Connect the utilities to be powered using suitable cables and plugs, in excellent condition.

6.4 Starting and stopping the engine

6.4.1 Starting the engine

- 1 - Turn the fuel valve (1) to the vertical position (ON).
- 2 - Check that all equipment power plugs are unplugged.

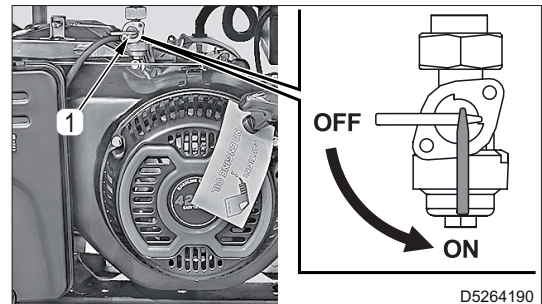

- 3 - Turn choke control lever (2) to the “closed” position.

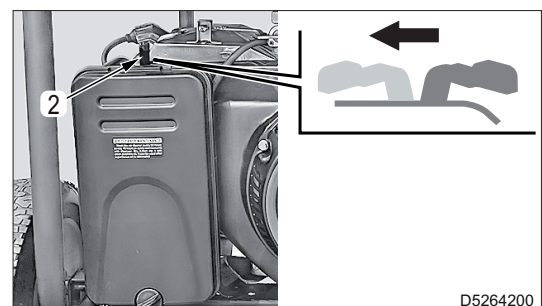

- 4 - Turn the engine start and stop switch to the ON position.

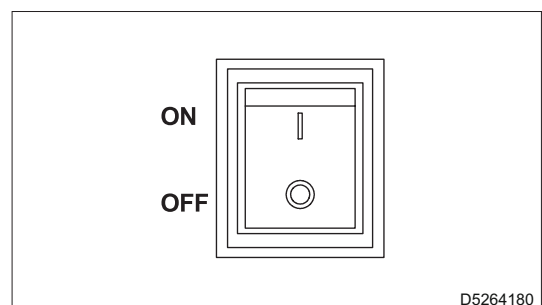

- 5 - Pull the start handle (3) until you feel resistance, then pull vigorously.
- 6 - Gently return the starter handle to its position, without hitting the engine.

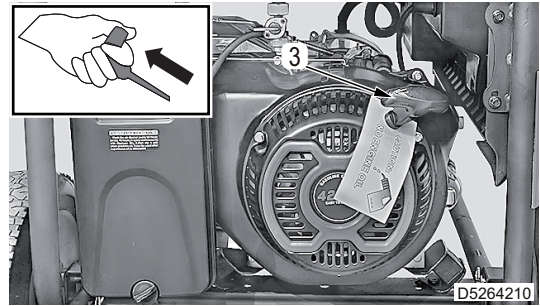

- 7 - Wait approximately 5 seconds and turn the choke control lever (2) to the "open" position.

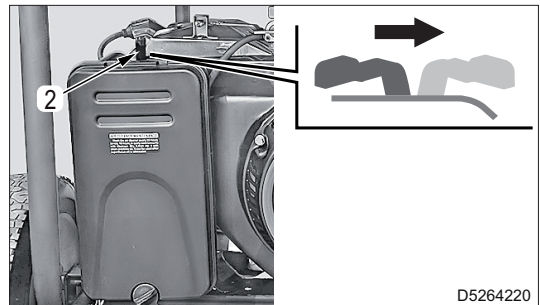

- 8 - Connect the equipment power plugs and turn the main switch of the machine to the ON position.

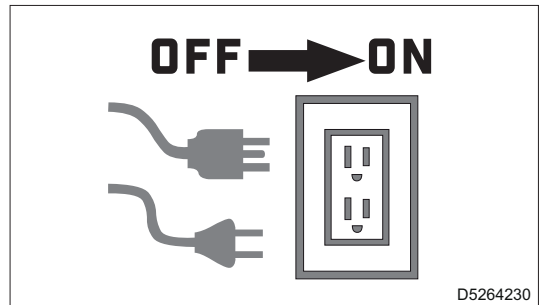

Stopping the engine

WARNING

- In case of emergency, turn the engine start and stop switch to the OFF position.

- 1 - Disconnect the equipment power plugs and turn the machine main switch to the OFF position.

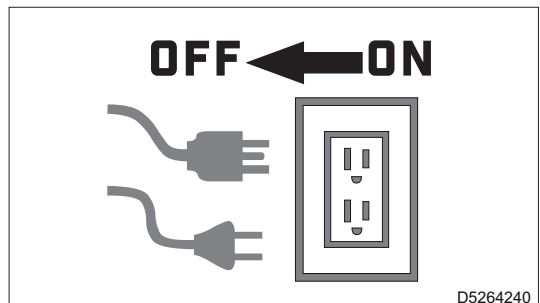

6. Operation

- 2 - Turn the engine start and stop switch to the OFF position.

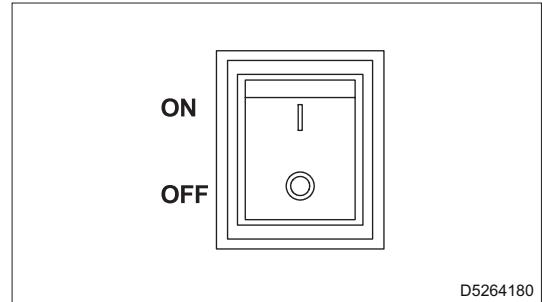

- 3 - Turn the fuel valve (1) to the horizontal position (OFF).

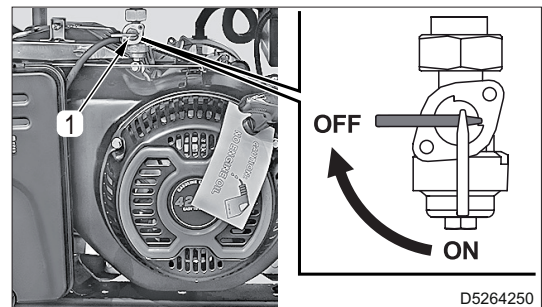

7. Maintenance



WARNING

- Before proceeding with maintenance, carefully read section “2. Safety”
- Place the generator on a level surface and remove the spark plug cap. for details see “7.6 Checking and replacing the spark plug”.

7.1 Ordinary Maintenance Schedule

Service interval	Description	Page
Every day	Check engine oil level	30
	Check engine air filter	31
After the first 20 hours	Replace engine oil	31
Every 50 hours	Clean air filter	31
Every 100 hours	Clean the spark plug	32
	Clean the carburetor tank	32
Every 300 hours	Replace spark plug	32
	Check and adjust the clearance of the valves	(*)
	Cleaning the fuel tank filter	(*)
Every 2 years	Check the fuel circuit	(*)

(*) These maintenance operations must be performed by a service centre.

7.2 Fuel

Only use gasoline and fill the tank with clean fuel.

- 1 - Stop the engine and wait for it to cool down.
 - 2 - Rotate the tank cap (1) counter-clockwise and remove it.
 - 3 - Fill the tank to the maximum level (Max.).
Check the fuel level on the fuel level indicator (2).
- Tank capacity:
GE3900 15 litres
GE6900 20 litres

WARNING

- Take care not to exceed the maximum level indicated in the figure.

- 4 - Wipe up any spilt fuel immediately.
- 5 - After refuelling, tighten the cap (1) securely.

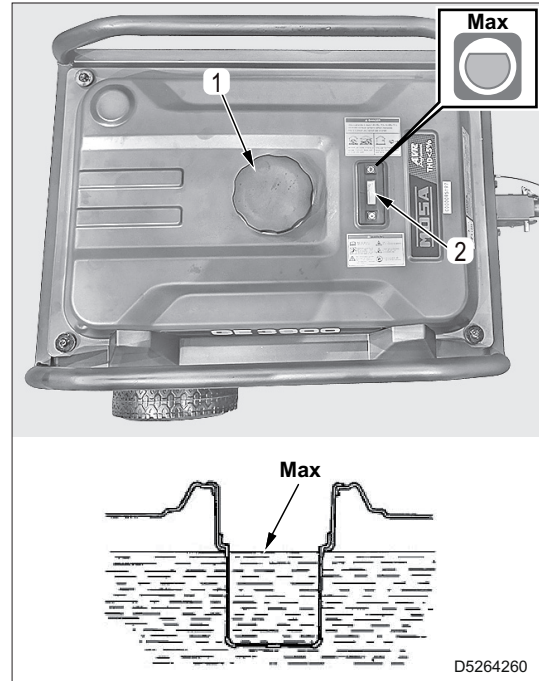

D5264260

7.3 Engine oil

- To ensure adequate protection of the engine and keep it efficient for a long time, use only oil for 4-stroke automotive engines. Using different oils can reduce the life of the engine.
- The viscosity must be appropriate to the ambient temperature.

7.3.1 Refuelling and checks

WARNING

- The machine is shipped without engine oil. Before starting the machine, fill it with oil.
- Before refuelling, read “2.9 Precautions during fuel and engine oil filling” carefully.
- Do not introduce more oil than indicated in the engine manual. Combustion of excess oil may result in increased engine revolutions.

- 6 - Remove the engine fill cap (1) and wipe the oil level dipstick (2) with a cloth.
- 7 - Insert the cap (1) into the filler neck without screwing it in, and remove it again to check the oil level on the dipstick (2).

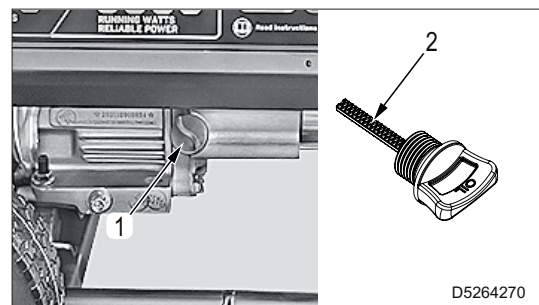

D5264270

7. Maintenance

8 - If the oil level is near or below the lower limit mark (Min.), fill the oil to the upper limit mark (Max.) (lower edge of the filler hole).

- Oil: SAE SJ 10W-30 - API service SJ or higher
- Tank capacity:
GE 3900 0.55 litres
GE 6900 1.1 litres

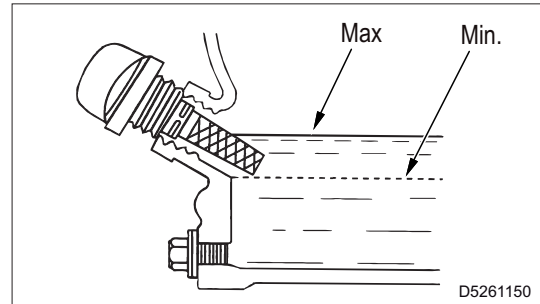

7.3.2 Replacement

- 1 - Place the generator on a level surface and start the engine for a few minutes to heat the oil.
- 2 - Place a container under the cap (1) to collect the drained oil.
- 3 - Unscrew the cap (1) and tilt the generator to let all the engine oil flow out.
- 4 - Fill with new oil. For the details, see “7.3.1 Refuelling and checks”.



7.4 Engine air filter

WARNING

- Clean the air filter more frequently if the generator set is used in dusty rooms.
- Do not use petrol or flammable solvents to clean the filter.

7.4.1 Check and clean

1 - Unscrew the knob (2) to open the cover (1).

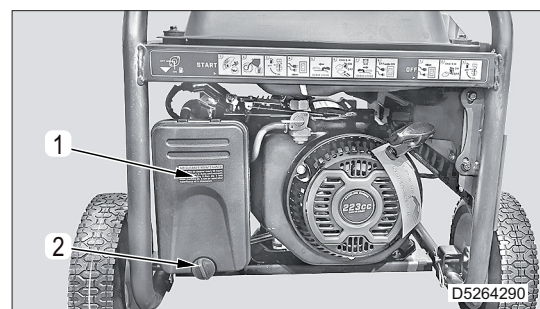

- 2 - Remove the air filter element (3).
- 3 - Wash the element with a solvent and dry it.
- 4 - Wet the element with oil and squeeze it out gently to remove any excess oil.

Note

- The element should be wet, but it shouldn't drip.

5 - Insert the element into the filter case ensuring that the surface adheres to the case.

6 - Close the cover (1) and tighten the knob (2).

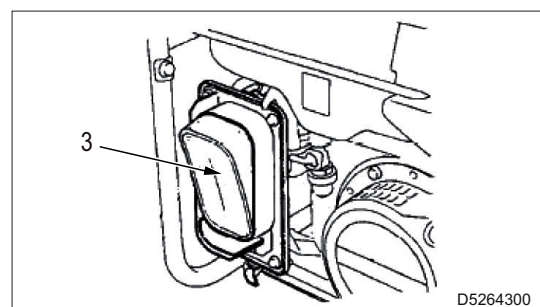

7.4.2 Replacement

Replace the filter every 50 hours of operation.

7.5 Cleaning the carburetor tank

1 - Turn the fuel valve (1) to the horizontal position (OFF).

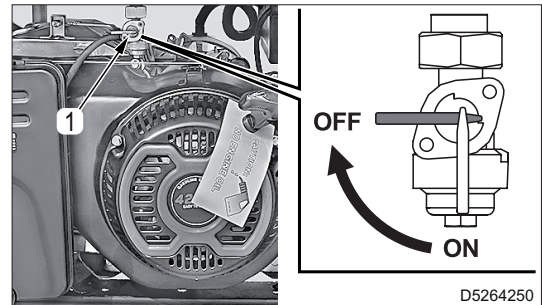

2 - Remove the carburetor tank (2).

3 - Clean the tank and OR seal with a non-flammable solvent.

4 - Install the carburetor tank (2).

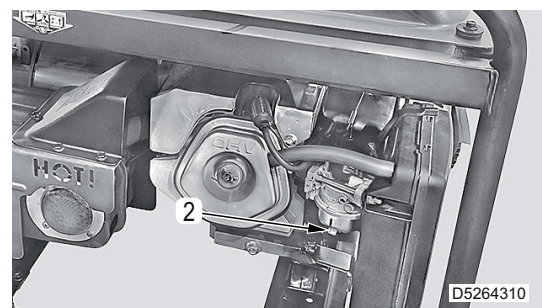

5 - Turn the valve (1) to the vertical position (ON) and check for fuel leaks.

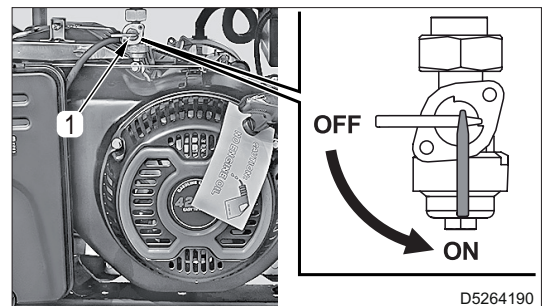

7.6 Checking and replacing the spark plug

1 - Remove the spark plug cap.

2 - Use the wrench supplied and unscrew the spark plug.

3 - Use a brass brush to remove soot and dirt and run a damp cloth to remove any residue.

4 - Check the colour of the porcelain insulator; if it is light brown, it is not necessary to replace it.

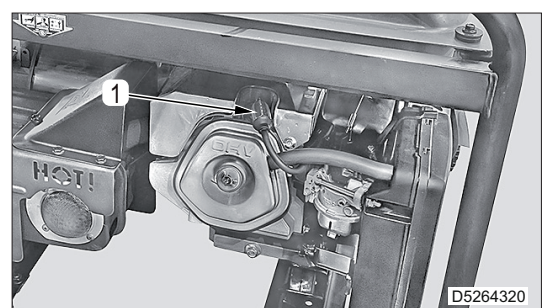

7. Maintenance

- 5 - Check that the distance between the electrodes (X) is correct.
 - Distance between the electrodes (X): 0.7- 0.8 mm
- 6 - If you need to replace the spark plug, replace it with one of the same type.
 - Spark plug type: F6RTC or F7RTC
- 7 - Install the cap (1).

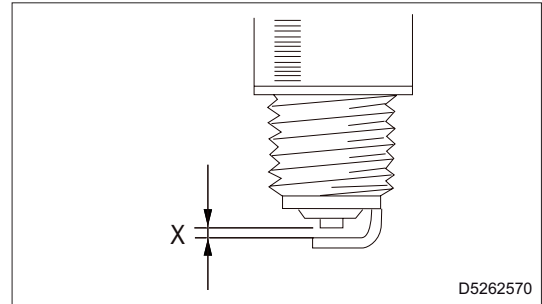

D5262570

7.7 Storage

- Carefully clean the fairings and all other machine parts.
- If the machine is not used for more than 30 days, make sure that the machine is protected from heat sources and from weather phenomena that can cause rust, corrosion of the components and damage to the machine.
- Completely empty the tank and the carburettor from the gasoline present, as it could irreparably damage the components of the engine power supply circuit if it deteriorates. Also, this reduces the fire risk of gasoline vapours.
- Protect the machine with a case and store it in a dry place.
- Use qualified personnel to carry out the operations necessary for storage.
- For correct engine storage, follow the instructions below.
 - Remove the spark plug, pour about 15 ml of engine oil into its seat and insert it again.
 - With the engine start switch set to OFF, pull the start handle until you feel the compression.

7.8 Disposal

WARNING

- **Before refuelling, read “2.11 Precautions for disposal of waste material” and “2.12 Disposal of the machine”.**

In the event of disposal of the machine or parts of it (oils, hoses, plastic materials, etc.), comply with the regulations in force in the country in which this operation is carried out.



MOSA div. della BCS S.p.A.

Viale Europa, 59 20047 Cusago (Milano) Italy
Tel.+39 - 0290352.1 Fax +39 - 0290390466 www.mosa.it