



GENERATING SET GE 12054 HZDT

The images are for reference



CARATTERISTICHE

- Low oil pressure automatic engine shut down and high temperature
- A recessed panel protects the sockets
- Protective frame
- IP54 brushless alternator
- Automatic voltage regulation "AVR"
- Isometer
- Circuit breaker
- Not compliant with noise directive 2000/14/EC



air cooled



diesel



three-phase



electric start

POWER RATINGS	
* Stand-By three-phase power (LTP)	12 kVA (9.6 kW) / 400 V / 17.3 A
* PRP three-phase power	11 kVA (8.8 kW) / 400 V / 15.8 A
* PRP single-phase power	6 kVA/kW / 230 V / 26 A
Frequency	50 Hz
Cos φ	0.8

* Output powers according to ISO 8528-1

DEFINITION

Valid declared powers up to the followings environmental conditions: temperature 25°C, altitude 100 meters above sea level)

LTP power: stand-by power: Maximum available power for use with variable loads for a yearly number of hours limited at 500 h. No overload is admitted.

PRP power: continue power with variable loads. Maximum power for use with variable loads for a yearly illimited nubers of hours.

COP power: continuous power with constant load. Maximum power for use with constant loads for a yearly unlimited numbers of hours.

ENGINE 3000 RPM

4-STROKE, DIRECT INJECTION	
Model	HATZ 1D90
* Stand-By net power	11.2 kWm (15.2 hp)
* PRP net power	10.2 kWm (13.9 hp)
* COP net power	/
Cylinders / Displacement	1 / 722 cm ³
Bore / Stroke	104 / 85 (mm)
Compression ratio	10.5 : 1
BMEP (Brake Mean Effective Pressure : LTP - PRP)	/
Speed governor type	Mechanical
FUEL CONSUMPTION	
110 % (Stand-by power)	3.6 lt./h
100 % to PRP	3.3 lt./h
75 % to PRP	2.5 lt./h
50 % to PRP	1.6 lt./h
COOLING SYSTEM	
Total system cap. - only engine	/
Fan air flow	/
LUBRICATION SYSTEM	
Total oil system capacity	/
Oil capacity in sump	1.9 lt.
Oil consumption at full load	< 0.028 kg./h

EXHAUST SYSTEM	
Maximum exhaust gas flow	/
Max. exhaust gas temp.	/
Maximum back pressure	/
External diameter exhaust pipe	/
ELECTRICAL SYSTEM	
Starter motor power	2 kW
Battery charging alternator cap.	16 A
Cold start	/
With cold start aid	- 10°C
AIR FILTER	
Combustion air flow	1.08 m ³ /min.
HEAT REJECTED AT FULL LOAD	
To exhaust system	/
To water and oil	/
Radiated to room	/
To charge cooler	/

ALTERNATOR

SYNCHRONOUS, THREE-PHASE, SELF-EXCITED, SELF-REGULATED, BRUSHLESS	
Continuous power	13 kVA
Stand-by power	14.5 kVA
Three phase voltage	400-415 Vac
Frequency	50 Hz
X _{0σ}	0.8
Model A.V.R.	Analogic
Voltage regulation acc.	± 1 %
Sustained short circuit current	3 I _n
Transient dip (100% load)	< 25 %
Recovery time	< 0.5 sec.
Efficiency at 100% load	/
Insulation	Class F/H
Connection - Terminals	Star - N°4
Electromagnetic compatibility (R.F.I. suppr.)	EN 61000-6-2 EN 61000-6-3
Waveform distortion - THD	< 5 %
Telephone interference - THF	/

REACTANCES (13 kVA - 400 V)	
Direct axis synchronous - X _d	/
Direct axis transient - X' _d	/
Subdirect axis transient - X'' _d	/
Quadrature axis synchronous - X _q	/
Quadr. axis subtransient - X'' _q	/
Negative sequence - X ₂	/
Zero sequence - X ₀	/
TIME CONSTANTS	
Transient - T' _d	/
Subtransient - T'' _d	/
Open circuit - T' _{do}	/
Armature - T _a	/
Short-circuit ratio K _{cc}	/
IP protection degree	IP 54
Cooling air flow	/
Coupling Bearing	Direct - N°1

GENERAL SPECIFICATIONS

Fuel tank capacity	18 lt.
Running time (75% to PRP)	7.2 h
Starter battery	12 Vdc -37Ah
IP protection degree	IP 54

Acoustic power L _{WA} (pressure L _{pA})	105 dB(A) (80 dB(A) @ 7m)
Performance class (ISO 8528)	G2

CONTROL PANEL

- Start and stop engine key
- Low oil pressure shutdown
- High engine temp. shutdown
- Battery charge warning light fault
- Hoursmeter
- Voltmeter
- Main circuit breaker
- Circuit breaker (three-phase output)
- Insometer
- Thermal circuit breakers for 230V Schuko sockets :2x 16A
- Output sockets : 1x400V 16A 3P+N+T CEE IP67
2x230V 16A 2P+T Schuko

WEIGHT - DIMENSIONS AND ACCESSORIES

GE 12054 HZDT



DRY WEIGHT MACHINE:
• 226 Kg

Generating set pictured may include optional accessories.



DIMENSIONS DRAW (mm)

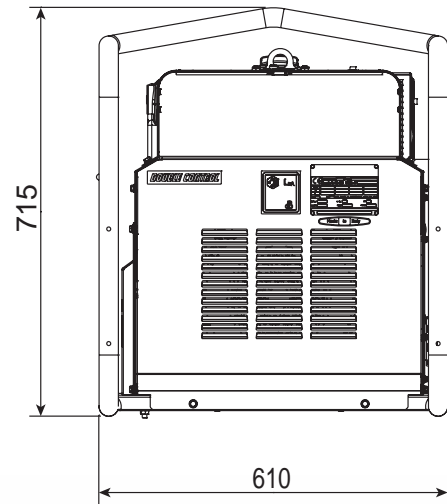
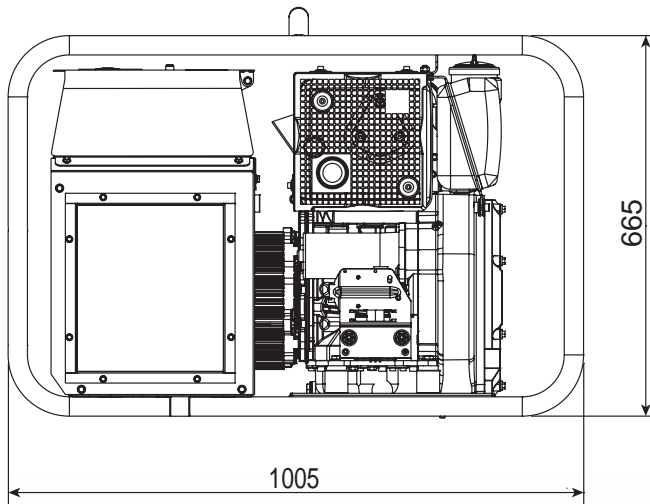

OPTIONS ON REQUEST

- Earthing
- Trolley CTM 14

VERSIONS ON REQUEST

- Sockets: 1x400V 32A 3P+N+T CEE
1x400V 16A 3P+N+T CEE
1x230V 16A 2P+T Schuko
- According to the DGVU-1203-032 regulation

FACTORY INSTALLATION OPTIONS

- /

GENERAL INFORMATION

COMPLIANCE GENERATING SETS WITH EC DIRECTIVES AND STANDARDS

- 2006/42 / EC (Machines Directive)
- 2014/35 / EU (Low Voltage Directive)
- 2014/30 / EU (EMC Directive)
- ISO 8528 (Reciprocating internal combustion engine driven alternating current generating sets)



ISO 9001:2008 - Cert. 0192

WARRANTY

All devices are covered by the manufacturer's warranty.

Non-contractual document. Specification subject to change without notice.

© MOSA - Viale Europa, 59 - 20047 Cusago (Milano) - Italy - phone +39-0290352.1 - fax + 39-0290390466 E-mail: export@mosa.it Web site: www.mosa.it

