

GENERATING SET GE 90 FSX



FEATURES

- Available version with STAGE 3A engine
- Bunded base suitable to contain any liquids leakage from engine avoiding environmental pollution
- Oil drain pump
- Fuel pre-filter with water separator
- Large doors for better and easy maintenance (air, oil, fuel filters replacement)
- Single point lifting eye and forklift pockets
- Control panel with digital control unit available with automatic or manual version
- Suitable for a wide range of uses in general construction
- Supersilenced
- Complies with regulation 2016/1628/EU FOR STATIONARY USE ONLY



POWER RATINGS

* Stand-By three-phase power (LTP)	90 kVA (72 kW) / 400V / 130A
* PRP three-phase power	83 kVA (66.4 kW) / 400V / 120A
* PRP single-phase power	66 kVA (52.8 kW) / 400V / 95.3A
Frequency	50 Hz
Cos φ	0.8

* Output powers according to ISO 8528-1

DEFINITION

Valid declared powers up to the followings environmental conditions: temperature 25°C, altitude 100 meters above sea level)

LTP power: stand-by power: Maximum available power for use with variable loads for a yearly number of hours limited at 500 h. No overload is admitted.

PRP power: continue power with variable loads. Maximum power for use with variable loads for a yearly illimited nubers of hours.

COP power: continuous power with constant load. Maximum power for use with constant loads for a yearly unlimited numbers of hours.

ENGINE 1500 RPM

4 STROKE, DIRECT INJECTION, TURBOCHARGED

Model	FPT (IVECO) N45SM3	FPT (IVECO) N45TE1F Stage 3A
* Stand-By net power	81 kW (110 hp)	80 kW (109 hp)
* PRP net power	73.3 kW (100 hp)	72.5 kW (99 hp)
* COP net power	58.4 kW (79 hp)	
Cylinders / Displacement	4 / 4500 cm ³ (4.5 lt.)	
Bore / Stroke	104 / 132 (mm)	
Compression ratio	17.5 : 1	
BMEP (Brake Mean Effective Pressure : LTP - PRP)	1777 kPa - 1617 kPa	
Speed governor type	Mechanical	Electronic
FUEL CONSUMPTION		
110 % (Stand-by power)	21.2 lt./h - 215.8 g/kWh	20.5 lt./h - 209.7 g/kWh
100 % to PRP	19.4 lt./h - 216.7 g/kWh	18.8 lt./h - 212.5 g/kWh
75 % to PRP	14.3 lt./h - 215.4 g/kWh	14.7 lt./h - 220 g/kWh
50 % to PRP	9.6 lt./h - 214.4 g/kWh	11.5 lt./h - 234.5 g/kWh
COOLING SYSTEM	Water	
Total system cap. - only engine	10 lt - 8.5 lt.	
Fan air flow	132 m ³ /min.	
LUBRIFICATION SYSTEM		
Total oil system capacity	12.8 l	
Oil capacity in sump	8.5 lt. ÷ 5.5 lt.	
Oil consumption at full load	< 0.023 l/h	

EXHAUST SYSTEM

Maximum exhaust gas flow	5.75 kg/mim.	8.6 kg/mim.
Max. exhaust gas temp.	516 °C	430 °C
Maximum back pressure	5 kPa (0.05 bar)	5 kPa (0.05 bar)

External diameter exhaust pipe /

ELECTRICAL SYSTEM

	12 Vdc	
Starter motor power	3 kW	
Battery charging alternator cap.	90 A	
Cold start	- 10 °C	
With cold start aid	- 25°C	

AIR FILTER

Combustion air flow	7.1 m ³ /min	
---------------------	-------------------------	--

HEAT REJECTED AT FULL LOAD

To exhaust system	543 kcal/kWh	630 kcal/kWh
To water and oil	412 kcal/kWh	416 kcal/kWh
Radiated to room	335 kcal/kWh	84 kcal/kWh
To charge cooler	/	115 kcal/kWh



ALTERNATOR

SYNCHRONOUS, THREE-PHASE, SELF-EXCITED, SELF-REGULATED, BRUSHLESS	
Continuous power	85 kVA
Stand-by power	94 kVA
Three phase voltage	380 - 415 Vac
Frequency	50 Hz
Cos φ	0.8
Model A.V.R.	MARK V
Voltage regulation acc.	$\pm 0.5\%$
Sustained short circuit current	3 In
Transient dip (100% load)	< 20 %
Recovery time	< 0.3 sec
Efficiency at 100% load	91 % (400V - Cos φ 0.8)
Insulation	Class H
Connection - Terminals	Star - N°12
Electromagnetic compatibility (R.F.I. suppr.)	EN 55011
Waveform distortion - THD	< 2 %
Telephone interference - THF	< 2 %

REACTANCES (85 kVA - 400V)	
Direct axis synchronuos - Xd	285 %
Direct axis transient - X'd	22.5 %
Subdirect axis transient - X''d	10.8 %
Quadrature axis synchronuos - Xq	160 %
Quadr. axis subtransient - X''q	12 %
Negative sequence - X2	11.4 %
Zero sequence - X0	2.5 %
TIME CONSTANTS	
Transient - T'd	0.071 sec
Subtransient - T''d	0.005sec
Open circuit - T'do	0.82 sec
Armature - Ta	0.005 sec
Short-circuit ratio Kcc	0.38
Grado di Protezione IP	IP 23
Cooling air flow	0.31 m ³ /sec.
Coupling Bearing	Direct SAE 3 -11 ½ - N°1

GENERAL SPECIFICATIONS

Fuel tank capacity	230 lt.	
Running time (75% to PRP)	16 h	15.5 h
Starter battery	12 Vdc -100Ah	
IP protection degree	IP 44	

* Measured acoustic power LwA (pressure LpA)	92 dB(A) (67 dB(A) @ 7m)
* Guaranteed acoustic power LwA (pressure LpA)	94 dB(A) (69 dB(A) @ 7m)
Performance class (ISO 8528)	G3

* Acoustic power according to European Directive 2000/14/CE

CONTROL PANEL

- Controller AMF 25
- Controller supply switch
- Siren
- Emergency stop button
- TCM 35 remote control plug
- Four pole circuit breaker
- PAC (ATS) plug - Automatic control panel only
- Battery charger - Automatic control panel only
- Earth terminal (PE)



AMF25 CONTROLLER CHARACTERISTICS	
Operating mode	<ul style="list-style-type: none"> • OFF - MAN. - AUTO - TEST
Display	<ul style="list-style-type: none"> • Graphic back-light LCD display 128x64 pixels
LEDs	<ul style="list-style-type: none"> • Gen-set voltage OK • Gen-set failure • GCB ON (only for Automatic transfer unit) • Mains voltage OK (only for Automatic transfer unit) • Mains failure (only for Automatic transfer unit) • MCB ON (only for Automatic transfer unit)
Buttons	<ul style="list-style-type: none"> • START button • STOP button • FAULT RESET button • RESET HORN button • MODE selection button • Pulsante chiusura/apertura GCB button • Pulsante chiusura/apertura MCB button • N° 4 buttons for controller programming
Generator Measures	<ul style="list-style-type: none"> • Voltage : L1-L2 / L2-L3 / L3-L1 - N-L1/N-L2/N-L3 • Current : I1 - I2 - I3 • Powers : kVA - kW - kVAR (totali e per fase) • Energy : kVAh - kWh - kVARh • Cos φ (medium and per phase) • Frequency
Engine Measures	<ul style="list-style-type: none"> • Water temperature • Oil pressure • Fuel level • Rpm meter • Battery voltage • Maintenance • Hours meter • Starts number
Generator Protections	<ul style="list-style-type: none"> • Overload • Overcurrent • Short circuit • Over-Undervoltage • Over-Underfrequency • Voltage asymmetry • Unbalanced current • Phase sequence
Engine Protections	<ul style="list-style-type: none"> • Overspeed • High water temperature warning • Low oil pressure warning • Low fuel level warning • Over-Under battery voltage • Battery charge alternator failure • Start failure • Stop failure • Emergency stop • Low water level shutdown (option)

AMF functions (Automatic control panel only)	<ul style="list-style-type: none"> • Measure mains voltage : L1-L2 / L2-L3 / L3-L1 - N-L1/N-L2/N-L3 • Measure mains frequency • Three phase detection • Over-Under mains voltage • Over-Under mains frequency • Voltage asymmetry • Phase sequence • Dual mutual stand-by application
Features	<ul style="list-style-type: none"> • Event log and alarms • 2 tests run scheduler (Automatic test or scheduled starts) • Engine idle management (Idle) • Remote Start and Stop • Pre-heating • 2 selectable languages (other languages available) • Setpoints adjustable via controller buttons or PC • Direct connection to engines with ECU via Can bus J1939 • Configurable inputs and outputs (only via PC) • IP65 protection • Operation temperature: -20°C / +70°C
Communication	<ul style="list-style-type: none"> • RTU Modbus (optional board with RS232 & RS485 outputs is needed) • TCP/IP Modbus (optional Ethernet board with RJ45 output is needed) • SNMP Modbus (optional Ethernet board with RJ45 output is needed) • Internet (optional Ethernet board optional is needed) • GSM/GPRS (integrated Modem board optional is needed) for Gen-set remote control via SMS or internet

CONTROL PANEL VERSION WITH OUTPUT SOCKETS	
SOCKETS Each socket is protect by own automatic switch. Circuit breaker for 125A and 63A sockets. GFI and circuit breaker 30mA for 32A and 16A socket.	1x 400V 125A 3P+N+T CEE 1x 400V 63A 3P+N+T CEE 1x 400V 32A 3P+N+T CEE 1x 400V 16A 3P+N+T CEE 1x 230V 16A 2P+T CEE 1x 230V 16A 2P+T SCHUKO

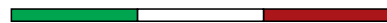

WEIGHT - DIMENSIONS AND ACCESSORIES

GE 90 FSX



DRY WEIGHT MACHINE:

- 1580kg
- 1630kg (Stage 3A)

Generating set pictured may include optional accessories.



DIMENSIONS DRAW

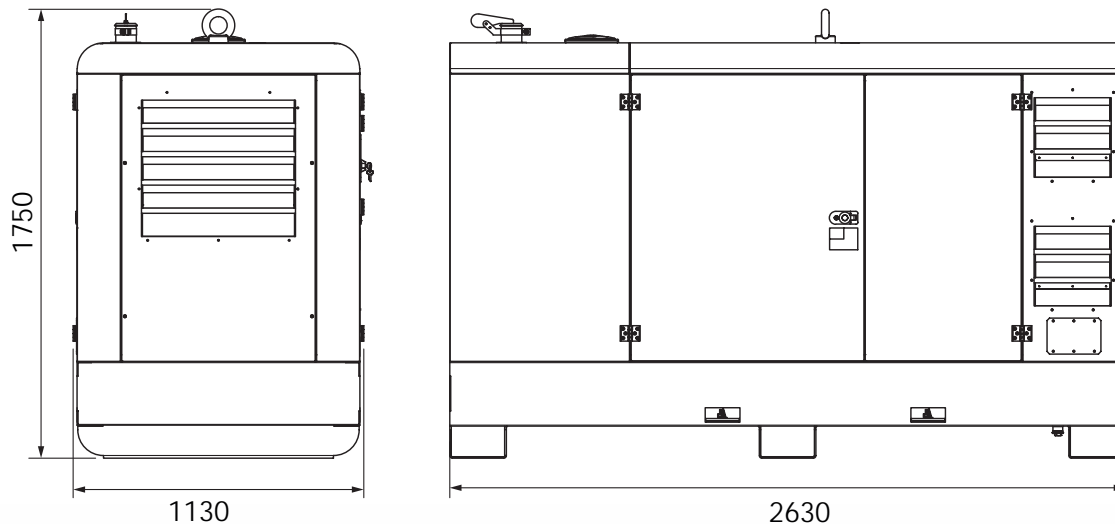

OPTIONS ON REQUEST

- Automatic transfer switch unit (ATS) PAC 111-M (160A)
- Remote control TCM35
- Earthing kit



VERSIONS ON REQUEST

- The electrical panel with Sockets CEE
- Manual digital control panel (without sockets)
- Parallel switch board



FACTORY INSTALLATION OPTIONS

- Engine water heater WH
- Spark arrestor
- Tank 350l
- 3-way valve fuel system with quick connection for external fuel tank supply
- Main battery switch
- Low level water sensor
- PMG - permanent magnet alternator excitation
- Electronic leakage relay
- Isometer
- Volt adjustable from control panel
- Plug-in board with RS232 & RS485 output for RTU Modbus protocol
- Ethernet plug-in board with RJ45 output for TCP/IP Modbus protocol - SNMP Modbus - Internet
- Plug-in board with integrated GSM/GPRS Modem for Gen-set remote control via SMS or Internet

GENERAL INFORMATION

COMPLIANCE GENERATING SETS WITH EC DIRECTIVES AND STANDARDS

2006/42 / EC (Machinery Directive)

2014/35 / UE (Low Voltage Directive)

2014/30 / UE (Electromagnetic Compatibility Directive)

ISO 8528 (Reciprocating internal combustion engine driven alternating current generating sets)



ISO 9001:2015 - Cert. 0192

WARRANTY

All devices are covered by the manufacturer's warranty.

Non-contractual document. Specification subject to change without notice.

© MOSA - Viale Europa, 59 - 20047 Cusago (Milano) - Italy - phone +39-0290352.1 - fax + 39-0290390466 E-mail: info@mosa.it Web site: www.mosa.it

